

### Specifications

Length.....	17 1/2"
Weight.....	5 3/8 lbs.
Height.....	5"
Air inlet.....	1/4" NPT
Recommended hose size.....	3/8" I.D.
Average air consumption.....	6 CFM
Maximum operating pressure.....	60-90 psi
Pad size.....	2 1/2" x 17 1/2"
Paper size.....	2 3/4" x 17 1/2"

### Parts Breakdown for FP-8222

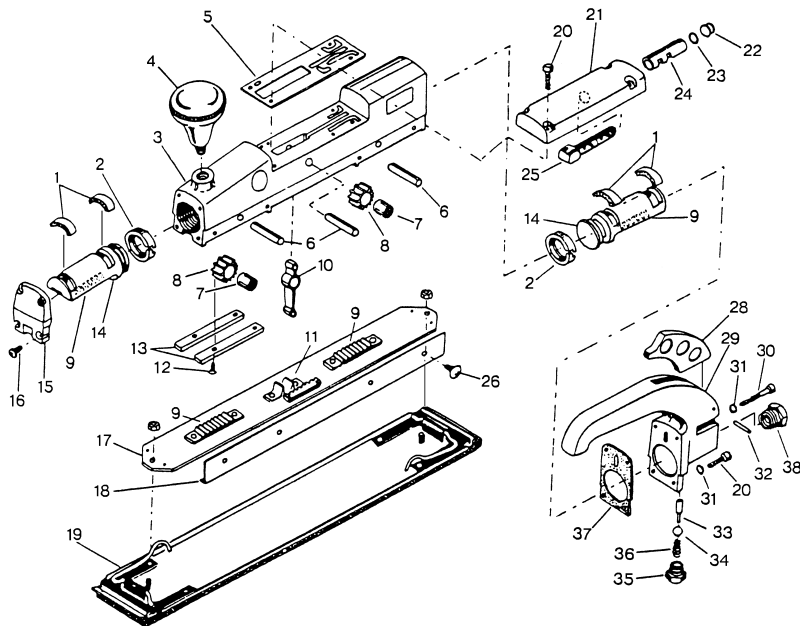

### Replacement Parts for

Ref.	Description	Part #	Ref.	Description	Part #
1	Felt (4)	8900156	20	Cap Screw (6)	8900176
2	Piston Ring (4)	8900157	21	Switch Valve Case	8900177
3	Housing-Double Piston	8900158	22	Plug	8900178
4	Knob	8729320	23	O-Ring	81008680
5	Case Gasket	8900160	24	Switch Sleeve	8900179
6	Pinion Pin (3)	8900161	25	Switch Valve	8900180
7	Needle Bearing (2)	8900162	26	Screw (8)	8900181
8	Pinion (2)	8900163	28	Lever	8900183
9	Rack (4)	8900164	29	Valve Handle	8900184
10	Arm	8900165	30	Cap Screw	8900185
11	Arm Drive	8900166	31	Washer (4)	8729035
12	Shoe Screw (8)	8900167	32	Roll Pin	8729167
13	Wear Shoe (4)	8900168	33	Valve Pin	8729305
14	Piston (2)	8900169	34	Valve	8900186
15	Housing Cap	8900170	35	Valve Screw	8729301
16	Screw (4)	8900171	36	Valve Spring	8729300
17	Carrier-Double Piston	8900172	37	Valve Gasket	8900187
18	Side Strap (2)	8900174	38	Inlet Bushing	8729162
19	Shoe w/Nuts	822219			

### Florida Pneumatic's Limited Warranty

Florida Pneumatic warrants their tools to be free from defects in material and workmanship for one year from the date of purchase. This warranty does not apply to tools which have been abused, misused, modified or repaired by someone other than Florida Pneumatic or their authorized service centers. If a Florida Pneumatic tool proves defective in material or workmanship within one year after purchase, return it to any authorized service center or Florida Pneumatic freight prepaid. Please enclose your name, address and adequate proof of purchase and a short description of the defect. Florida Pneumatic will, at their option, repair or replace defective tools, free of charge. Repairs or replacements are warranted as described above for the remainder of the original warranty period. Florida Pneumatic's sole liability and your exclusive remedy under this warranty is limited to repair or replacement of the defective tool. There are no other warranties expressed or implied and Florida Pneumatic shall not be liable for incidental, consequential or special damages, or any other damages, costs or expense of repair or replacement as described above.

**WARNING** - Never use tool without proper eye protection.