

PLEASE READ AND FOLLOW ALL WARNINGS



FP775 & FP775L & FP775C

3/4" Pistol Impact

Read Operating Instructions

Always become familiar with all the instructions and warnings before operating any power tool.

Always Wear Approved Eye Protection

Impact resistant eye protection should meet or exceed the standards as set forth in the United States ANSI Z87.1, Occupational and Educational Eye and Face Protection. Look for the marking Z87.1 on your eye protection to insure that it is an approved style. For further information, ANSI Z87.1, Occupational and Educational Eye and Face Protection, is available from the American National Standards Institute, Inc., 11 West 42nd Street, New York, NY 10036.

Hearing Protection is Recommended

Hearing protection should be used when the noise level exposure equals or exceeds an 8 hour time-weighted average sound level of 85 dBA. Process noise, reflective surfaces, other tools being operated nearby, all add to the noise level present in your work area. If you are unable to determine your noise level exposure, we recommend the use of hearing protection.

Avoid Prolonged Exposure to Vibration

Tools can vibrate during use. Prolonged exposure to vibration or very repetitive hand and arm movements, can cause injury. Stop using any tool if discomfort, tingling feeling or pain occurs. You should consult your physician before resuming use of the tool.

90 PSIG Maximum

This tool is designed to operate at

an air pressure of 90 pounds per square inch gauge pressure (90 PSIG) maximum, at the tool. Use of higher air pressure can, and may cause injury. Also, the use of higher air pressure places the internal components under loads and stresses they were not designed for, causing premature failure. The air supply should be clean and dry, preferably lubricated. For best results, drain the moisture from your compressor daily.

WARNING:

Some dust created by power sanding, sawing, grinding, drilling, and other construction activities contains chemicals known to cause cancer, birth defects or reproductive harm. Some examples of these chemicals are:

- Lead from lead-based paints
- Crystalline silica from bricks, cement and other masonry products
- Arsenic and chromium from chemically treated lumber

Your risk from these exposures varies, depending on how often you do this type of work. To reduce your exposure to these chemicals, work in a well-ventilated area and work with approved safety equipment such as those dust masks that are specially designed to filter out microscopic particles.

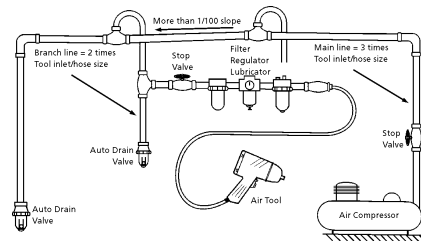

Description

Florida Pneumatic 3/4" impact wrenches are designed for a wide variety of MRO and assembly applications. This tool features a built-in power regulator for convenient power output adjustment, front and rear housing protector and a ring type socket retainer for quick and easy socket changes.



Safety Instructions

The following instructions are furnished as general guidelines for use of your pneumatic tool. They cannot comprehensively cover all possible or conceivable uses of the subject tool. For additional information on the safe use of air tools, we advise you to obtain a copy of ANSI B186.1 Safety Code for Portable Air Tools, available from the following source:

American National Standards Institute, Inc.
11 West 42nd Street
New York, NY 10036.

The use of the word "shall" in the following instructions, indicates that adherence to the particular requirement is necessary to conform to ANSI B186.1.

Tool Application and Usage

Portable tools shall be used only for the purposes intended in their design and within the capacity for which they were intended and rated. It shall be the tool owner's and/or employer's responsibility to instruct each operator in the safe use of the tool. Tools shall not be used without guards and safety

devices as furnished by the manufacturer. Where an air tool is modified or altered, the modifier shall provide the safeguards to enable it to be safely used in the operations intended and to comply with any applicable provisions as contained in ANSI B186.1.

Tool Installation

Pressure regulators shall be used to limit air pressure to the rated pressure where the supply pressure exceeds the tool's rated pressure. Air hoses and lines shall be relieved of compressed air before being disconnected or disjoined, unless there is automatic valve closing protection at the joint being separated. Synthetic lubricants which can cause deterioration of elastomer seals shall not be used in air systems of air tools.

Tool Maintenance

It shall be the tool owner's and/or employer's responsibility to assure that tools are maintained in a safe operating condition. Tool maintenance and repair shall be performed by authorized, trained, competent personnel. Tools shall be disconnected from their compressed air supply before repairs are attempted. Repairs shall be consistent with the manufacturer's recommended procedures. Tool, hoses and fittings shall be replaced if unsuitable for safe operation. It shall be the tool owner's and/or employer's responsibility to keep required rating markings and warnings on the tool in legible condition.

Florida Pneumatic Manufacturing Corporation
851 Jupiter Park Lane, Jupiter, Florida 33458
Toll Free 1-800-327-9403

Read these instructions carefully before attempting to install, operate or service this Florida Pneumatic product. Failure to comply with the instructions could result in personal injury and/or property damage! Retain these instructions for future reference.

FPMC

Drive size.....	3/4"
Free speed (No Load).....	4,600 RPM
Impacts per minute.....	1,200 IPM
Maximum torque.....	900 ft.lbs.
Bolt Capacity.....	1"
Weight.....	10.6 lbs.
.Overall length.....	14 3/8"
Average air consumption.....	4.2 CFM
Recommended hose size.....	3/8" I.D.
Air inlet.....	1/4" NPT
Maximum Air Pressure.....	90 psi

Parts Breakdown for FP775 & FP775L & FP775C

USE ONLY IMPACT SOCKETS & ACCESSORIES

Sockets and accessories used shall be of the impact socket type. Always check sockets, retainers and drives regularly for wear or damage and replace whenever necessary

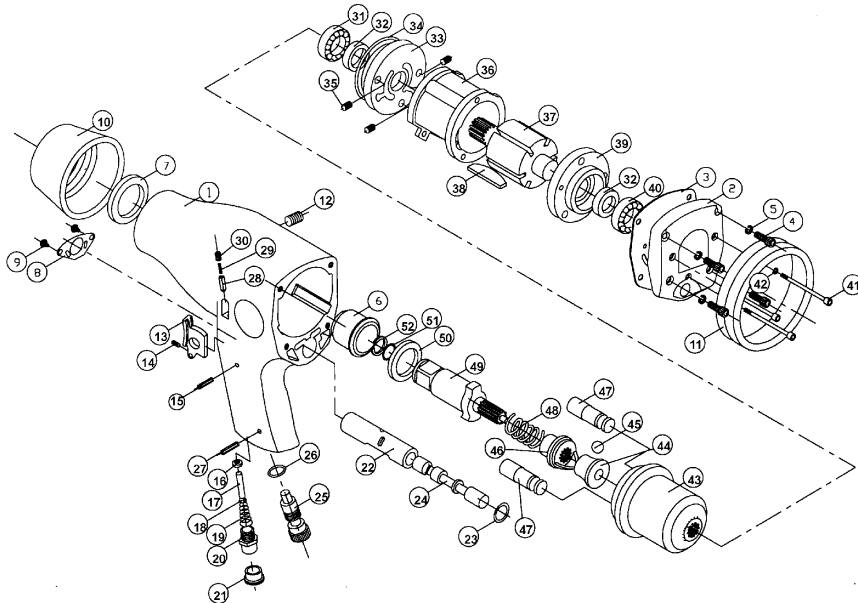

Replacement Parts for FP775 & FP775L & FP775C

Ref.	Description	Part #	Ref.	Description	Part #
1	Motor Housing	9826001	30	Screw	9811108
2	End Cap	9826034	31	Bearing	9826028
3	En Cap Gasket	9826035	32	Oil Seal	9826036
4	Hex Socket Bolt (4)	9826102	33	Front End Plate	9826027
5	Spring Washer (4)	9826143	34	O-Ring	9826116
6	Anvil Bushing	9826017	35	Recoil (3)	9826114
7	Oil Seal	9826037	36	Cylinder	9826024
8	Muffle Steel Cover	9826038	37	Rotor	9818025
9	Phillips PanScrew (2)	9811106	38	Rotor Blade (6)	9826026
10	Front Protecting Rubber	9826045	39	Rear End Plate	9826029
11	Rear Protecting Rubber	9826069	40	Bearing	9826030
12	Clamp Screw	9811105	41	Screw (3)	9826101
13	Trigger	9826004	42	Washer (3)	9811144
14	Clamp Screw	9832104	43	Hammer Cage	9826019
15	Spring Pin	9811129	44	Drive Cam Base	9826043
16	Throttle Bushing	9826006	45	Ball	9826061
17	Throttle Pin	9826007	46	Drive Cam	9826022
18	Steel Ball	9826008	47	Hammer Bar (2)	9826021
19	Compression Spring	9811009	48	Spring	9826062
20	Hose Fitting	9811010	49	Anvil	9826018
21	Dust Cover	9811067	•	Anvil (6" ext)	9826018L
22	Valve Screw	9826002	50	Washer	9826016
23	O-Ring	9824118	51	O-Ring	9826121
24	Reverse Valve	9826003	52	Anvil Collar	9826066
25	Air Regulator	9826012	53	O-Ring	9826140
26	O-Ring	9826117	•	Boot	8731219
27	Pin	9826128	(•)	Not Shown.	
28	Pin	9826125			
29	Spring	9811068			

Limited Warranty

Florida Pneumatic warrants its tools to be free from defects in material and workmanship for two years from the date of purchase. This warranty does not apply to tools which have been abused, misused, modified or repaired by someone other than Florida Pneumatic or its authorized service centers. If a Florida Pneumatic proves defective in material of workmanship within two years after purchase, return it to any authorized service center or to Florida Pneumatic, freight prepaid. Please enclose your name, address and adequate proof of purchase date with a brief description of the defect. Florida Pneumatic will, at its option, repair or replace defective tools, free of charge. Repairs or replacements are warranted as described above for the remainder of the warranty period. Florida Pneumatic's sole liability and your exclusive remedy under this warranty is limited to repair or replacement of the defective tool. There are no other warranties expressed or implied and Florida Pneumatic shall not be liable for incidental, consequential or special damages, or any other damages, costs or expense of repair or replacement as described above.