

Drive size.....1/2"  
 Free speed (No load).....7,000 RPM  
 Impacts per minute.....1,200 IPM  
 Torque range.....500 Ft. Lbs. @ 90 psi  
 Bolt Capacity.....9/16"  
 Weight.....5-3/4 lbs.  
 Overall length.....7 1/4"  
 Average air consumption.....8 CFM  
 Recommended hose size.....3/8" I.D.  
 Air inlet.....1/4" NPT  
 Maximum operating pressure.....90 psi

**Parts Breakdown for FP744L**

**USE ONLY IMPACT SOCKETS & ACCESSORIES**

Sockets and accessories used shall be of the impact socket type. Always check sockets, retainers and drives regularly for wear or damage and replace whenever necessary

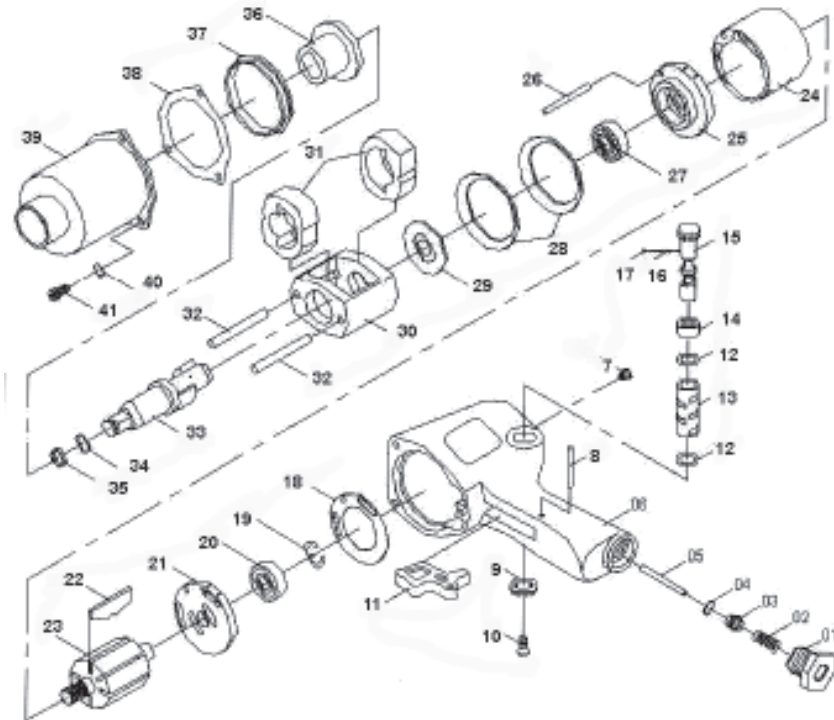

**Replacement Parts for FP744L**

Ref.	Description	Part #	Ref.	Description	Part #
1	Air Inlet Bushing	9111-00702	22	Rotor Blade (6)	9225-00102
2	Throttle Valve Spring	9113-00309	23	Rotor	9610-00102
3	Throttle Valve	9225-00402	24	Cylinder	9241-00102
4	O-Ring	9149-0030201	25	Front Plate	9543-00402
5	Valve Stem	9111-00403	26	Guide Pin	9111-00408
6	Motor Housing	9440-00105	27	Ball Bearing	9149-0010701
7	Grease Fitting	9211-00901	28	Conical Washer (2)	9112-01302
8	Trigger Pin	9111-00411	29	Hammer Frame	9112-01306
9	Reverse Valve Knob	9141-00703		Rear Spacer	
10	Screw	9173-120512	30	Hammer Cage	9543-00302
11	Trigger	9225-00301	31	Hammer (2)	9243-00202
12	Bushing Seal (2)	9149-0030302	32	Hammer Pin (2)	9111-00404
13	Reverse Valve Bushing	9111-00501	33	Anvil	9410-003021
14	Detent Bushing	9141-00501	34	Retainer O-Ring	9149-00302
15	Reverse Valve	9111-00603	35	Socket Retainer	9113-00401
16	Detent Spring	9113-00307	36	Anvil Bushing	9141-00603
17	Detent Ball	9149-00201	37	Hammer Housing	9141-00601
18	Gasket	9130-01501		Pilot Ring	
19	Retaining Ring	9113-00603	38	Gasket	9130-01502
20	Ball Bearing (2)	9149-00104	39	Hammer Housing	9312-01501
21	Rear Plate	9543-00502	40	Spring Washer (3)	9173-140001
			41	Screw (3)	9173-140001
			*42	2" Extended Anvil	9410-003021
			*	Not Shown	

**Limited Warranty**

Florida Pneumatic warrants its tools to be free from defects in material and workmanship for two years from the date of purchase. This warranty does not apply to tools which have been abused, misused, modified or repaired by someone other than Florida Pneumatic or its authorized service centers. If a Florida Pneumatic proves defective in material of workmanship within one year after purchase, return it to any authorized service center or to Florida Pneumatic, freight prepaid. Please enclose your name, address and adequate proof of purchase date with a brief description of the defect. Florida Pneumatic will, at its option, repair or replace defective tools, free of charge. Repairs or replacements are warranted as described above for the remainder of the warranty period. Florida Pneumatic's sole liability and your exclusive remedy under this warranty is limited to repair or replacement of the defective tool. There are no other warranties expressed or implied and Florida Pneumatic shall not be liable for incidental, consequential or special damages, or any other damages, costs or expense of repair or replacement as described above.