

## MODEL FP1050 Scaler

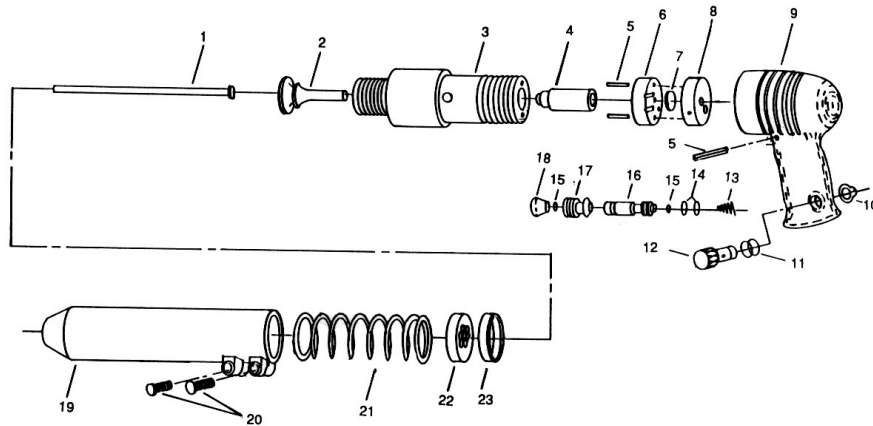

### Parts List

Ref. No.	Description	Part No.	Ref. No.	Description	Part No.
1	Set of 19 needles	109020	14	O-ring (2)	115160
2	Anvil	109010	15	O-ring (2)	115120
3	Barrel w/112020	425660	16	Trigger Valve stem	120220
4	Piston	112020	17	Trigger Valve body	120120
5	Retaining pin (3)	111230	18	Trigger button	120310
6	Lower valve block	121110	19	Needle Scaler Housing	109060
7	Flipper valve	121010	20	Cap Screw (2)	109070
8	Upper valve block	121130	21	Spring	109050
9	Handle	264268	22	Needle Holder	109030
10	Retaining ring	115020	23	Buffer	109040
11	O-ring (2)	115110		Scaler attachment Complete	109080
12	Regulator knob	111110			
13	Spring	118020			