

PLEASE READ AND FOLLOW ALL WARNINGS



UT8966

POSITIVE CLUTCH SCREWDRIVER

Read Operating Instructions

Always become familiar with all the instructions and warnings before operating any power tool.

Always Wear Approved Eye Protection

Impact resistant eye protection should meet or exceed the standards as set forth in the United States ANSI Z87.1, Occupational and Educational Eye and Face Protection. Look for the marking Z87.1 on your eye protection to insure that it is an approved style. For further information, ANSI Z87.1, Occupational and Educational Eye and Face Protection, is available from the American National Standards Institute, Inc., 11 West 42nd Street, New York, NY 10036.

Hearing Protection is Recommended

Hearing protection should be used when the noise level exposure equals or exceeds an 8 hour time-weighted average sound level of 85 dBA. Process noise, reflective surfaces, other tools being operated nearby, all add to the noise level present in your work area. If you are unable to determine your noise level exposure, we recommend the use of hearing protection.

Avoid Prolonged Exposure to Vibration

Tools can vibrate during use. Prolonged exposure to vibration or very repetitive hand and arm movements, can cause injury. Stop using any tool if discomfort, tingling feeling or pain occurs. You should consult your physician before resuming use of the tool.

90 PSIG Maximum

This tool is designed to operate at

an air pressure of 90 pounds per square inch gauge pressure (90 PSIG) maximum, at the tool. Use of higher air pressure can, and may cause injury. Also, the use of higher air pressure places the internal components under loads and stresses they were not designed for, causing premature failure. The air supply should be clean and dry, preferably lubricated. For best results, drain the moisture from your compressor daily.

WARNING:

Some dust created by power sanding, sawing, grinding, drilling, and other construction activities contains chemicals known to cause cancer, birth defects or reproductive harm. Some examples of these chemicals are:

- Lead from lead-based paints
- Crystalline silica from bricks, cement and other masonry products
- Arsenic and chromium from chemically treated lumber

Your risk from these exposures varies, depending on how often you do this type of work. To reduce your exposure to these chemicals, work in a well-ventilated area and work with approved safety equipment such as those dust masks that are specially designed to filter out microscopic particles.

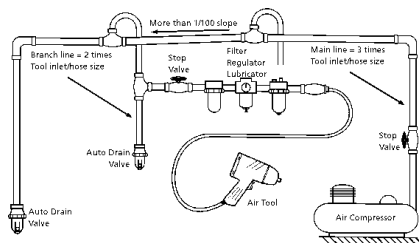

Description

The Universal Tool model UT8966 Positive Clutch Screwdriver is equipped with a 1/4" hexagonal quick change driver bit holder. Fully reversible with the flip of the lever makes this a quick and easy tool to use. Ideal for sheet metal, wood and self-tapping screws. Includes a 360° adjustable side handle to assist operator control, through handle exhaust to reduce noise and a variable trigger to make starting screws easier.



UT8966

Safety Instructions

The following general instructions are furnished as general guidelines for use of your pneumatic tool. They cannot comprehensively cover all possible or conceivable uses of the subject tool. For additional information on the safe use of air tools, we advise you to obtain a copy of ANSI B186.1 Safety Code for Portable Air Tools, available from the following source:

American National Standards Institute, Inc.
11 West 42nd Street
New York, NY 10036.

The use of the word "shall" in the following instructions, indicates that adherence to the particular requirement is necessary to conform to ANSI B186.1.

Tool Application and Usage

Portable tools shall be used only for the purposes intended in their design and within the capacity for which they were intended and rated. It shall be the tool owner's and/or employer's responsibility to instruct each operator in the safe use of the tool. Tools shall not be used without guards and safety

devices as furnished by the manufacturer. Where an air tool is modified or altered, the modifier shall provide the safeguards to enable it to be safely used in the operations intended and to comply with any applicable provisions as contained in ANSI B186.1.

Tool Installation

Pressure regulators shall be used to limit air pressure to the rated pressure where the supply pressure exceeds the tool's rated pressure. Air hoses and lines shall be relieved of compressed air before being disconnected or disjoined, unless there is automatic valve closing protection at the joint being separated. Synthetic lubricants which can cause deterioration of elastomer seals shall not be used in air systems of air tools.

Tool Maintenance

It shall be the tool owner's and/or employer's responsibility to assure that tools are maintained in a safe operating condition. Tool maintenance and repair shall be performed by authorized, trained, competent personnel. Tools shall be disconnected from their compressed air supply before repairs are attempted. Repairs shall be consistent with the manufacturer's recommended procedures. Tool, hoses and fittings shall be replaced if unsuitable for safe operation. It shall be the tool owner's and/or employer's responsibility to keep required rating markings and warnings on the tool in legible condition.

Universal Tool

A Division of Florida Pneumatic Manufacturing Corporation
851 Jupiter Park Lane, Jupiter, Florida 33458
Toll Free 1-800-327-9403

Read these instructions carefully before attempting to install, operate or service this Universal Tool product. Failure to comply with the instructions could result in personal injury and/or property damage! Retain these instructions for future reference.

FPMC

PL-0270

Specifications

| | |
|-------------------------------|-----------------------|
| Free speed | 2,000 RPM |
| Bit retainer | 1/4" Hex Quick Change |
| Maximum Torque | 55 in./lb. |
| Weight | 2.5lbs. |
| Overall length | 8.5" |
| Average air consumption | 4 CFM |
| Air inlet | 1/4" NPT |
| Recommended hose size | 3/8" I.D. |
| Maximum air pressure | 90 PSI |

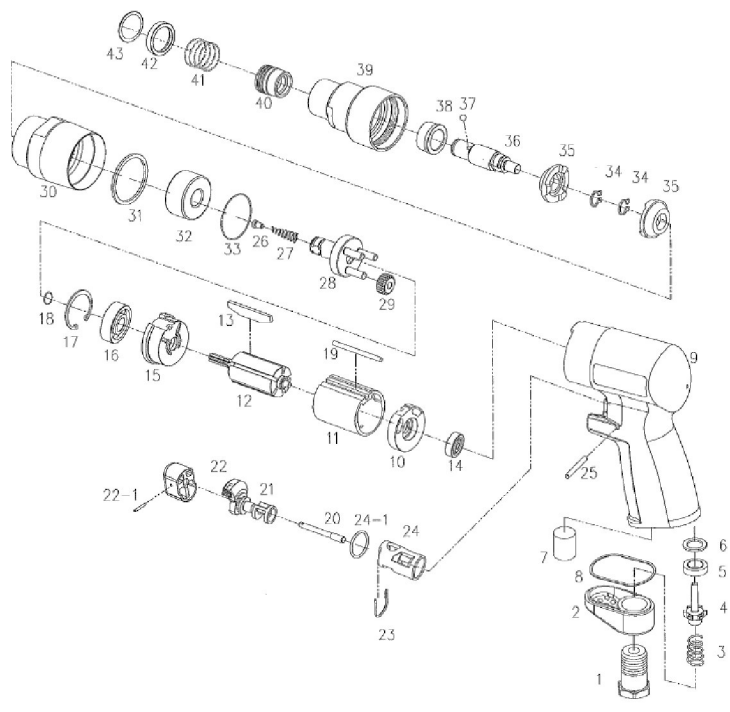
Parts Breakdown for UT8966

Replacement Parts

| REF | PART NO. | DESCRIPTION | REF | PART NO. | DESCRIPTION |
|------|-----------|-----------------|------|-----------|--------------------|
| 1 | 9389501 | AIR INLET | 23 | 9396623 | SPRING CLIP |
| 2 | 9389502 | DEFLECTOR | 24 | 9396624 | VALVE BUSHING |
| 3 | 9389503 | SPRING | 24-1 | 9396624-1 | O-RING |
| 4 | 9328804VN | VALVE | 25 | 9396625 | TRIGGER PIN |
| 5 | 9328835N | VALVE SEAT | 26 | 9396626 | SPRING GUIDE |
| 6 | 9328825SN | SPACER | 27 | 9396627 | SPRING |
| 7 | 9389507 | SILENCER | 28 | 9396628 | GEAR CARRIER |
| 8 | 9389502-1 | GASKET | 29 | 9396629 | IDLE GEAR (3) |
| 9 | 9396609 | HOUSING | 30 | 9396630E | GEAR HOUSING |
| 10 | 9396610 | REAR PLATE | 31 | 9396631 | WASHER |
| 11 | 9396611 | CYLINDER | 32 | 9396632 | BALL BEARING |
| 12 | 9396612 | ROTOR | 33 | 9396633 | O-RING |
| 13 | 9396613 | ROTOR BLADE (5) | 34 | 9596535 | RETAINING RING (2) |
| 14 | 9396614 | BALL BEARING | 35 | 9396635 | CLUTCH (2) |
| 15 | 9396615 | FRONT PLATE | 36 | 9396636 | WORK SPINDLE |
| 16 | 9396616 | BALL BEARING | 37 | 9STB3175 | STEEL BALL |
| 17 | 9396617 | RETAINING RING | 38 | 9396638 | SLEEVE BEARING |
| 18 | 9396618 | RETAINING RING | 39 | 9396639 | CLUTCH HOUSING |
| 19 | 9396619 | CYLINDER PIN | 40 | 9396640 | BALL RETAINER |
| 20 | 9396620 | VALVE STEM | 41 | 9589043 | SPRING |
| 21 | 9396621 | REVERSING VALVE | 42 | 9589032 | BIT WASHER |
| 22 | 9396622 | TRIGGER | 43 | 9589033 | BIT RING |
| 22-1 | 9589039 | PIN | | | |

Universal Tool's Limited Warranty

Universal Tool warrants their tools to be free from defects in material and workmanship for one year from the date of purchase. This warranty does not apply to tools which have been abused, misused, modified or repaired by someone other than Universal Tool or their authorized service centers. If a Universal Tool proves defective in material or workmanship within one year after purchase, return it to any authorized service center or Universal Tool freight prepaid. Please enclose your name, address and adequate proof of purchase and a short description of the defect. Universal Tool will, at their option, repair or replace defective tools, free of charge. Repairs or replacements are warranted as described above for the remainder of the original warranty period. Universal Tool's sole liability and your exclusive remedy under this warranty is limited to repair or replacement of the defective tool. There are no other warranties expressed or implied and Universal Tool shall not be liable for incidental, consequential or special damages, or any other damages, costs or expense of repair or replacement as described above.

Tool Operation and Maintenance

- Daily, before putting tool into operation, disconnect air hose and pour 1/4 oz. of air tool oil into the air inlet.
- Blow out air line to clear it of accumulated dirt and moisture. Connect tool and operate momentarily to allow oil to be carried through tool.

- Hose runs longer than 8 feet should be connected to a 1/2" ID hose to provide sufficient volume for proper performance.
- We recommend oil made exclusively for air tools or equivalents which include moisture absorbants, rust inhibitors, metal wetting agents and an EP (extreme pressure) additive.