

PLEASE READ AND FOLLOW ALL WARNINGS

Universal Tool

UT8748

4" Angle Cut-off Tool

Read Operating Instructions

Always become familiar with all the instructions and warnings before operating any power tool.

Always Wear Approved Eye Protection

Impact resistant eye protection should meet or exceed the standards as set forth in the United States ANSI Z87.1, Occupational and Educational Eye and Face Protection. Look for the marking Z87.1 on your eye protection to insure that it is an approved style. For further information, ANSI Z87.1, Occupational and Educational Eye and Face Protection, is available from the American National Standards Institute, Inc., 11 West 42nd Street, New York, NY 10036.

Hearing Protection is Recommended

Hearing protection should be used when the noise level exposure equals or exceeds an 8 hour time-weighted average sound level of 85 dBA. Process noise, reflective surfaces, other tools being operated nearby, all add to the noise level present in your work area. If you are unable to determine your noise level exposure, we recommend the use of hearing protection.

Avoid Prolonged Exposure to Vibration

Tools can vibrate during use. Prolonged exposure to vibration or very repetitive hand and arm movements, can cause injury. Stop using any tool if discomfort, tingling feeling or pain occurs. You should consult your physician before resuming use of the tool.

90 PSIG Maximum

This tool is designed to operate at

an air pressure of 90 pounds per square inch gauge pressure (90 PSIG) maximum, at the tool. Use of higher air pressure can, and may cause injury. Also, the use of higher air pressure places the internal components under loads and stresses they were not designed for, causing premature failure. The air supply should be clean and dry, preferably lubricated. For best results, drain the moisture from your compressor daily.

WARNING:

ONLY USE ACCESSORIES THAT ARE RATED TO RUN AT THE MAXIMUM SPEED (RPM) OR HIGHER.

Some dust created by power sanding, sawing, grinding, drilling, and other construction activities contains chemicals known to cause cancer, birth defects or reproductive harm. Some examples of these chemicals are:

- Lead from lead-based paints
- Crystalline silica from bricks, cement and other masonry products
- Arsenic and chromium from chemically treated lumber

Your risk from these exposures varies, depending on how often you do this type of work. To reduce your exposure to these chemicals, work in a well-ventilated area and work with approved safety equipment such as those dust masks that are specially designed to filter out microscopic particles.

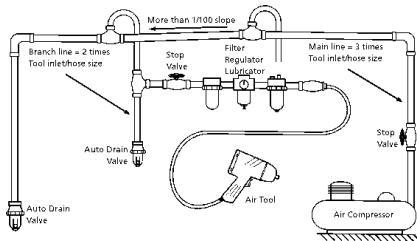

Description

Ergonomic cushion comfort grip for comfort and reduced vibration and 360 degree swivel guard and swivel air inlet for ultimate maneuverability in confined work area. Guard and mounting flanges designed for use with Type 1 wheels. Total angle head height 2.5". Best for cutting pipes in boiler installation and repair, petro chemical plant maintenance; as well as cutting bolts and threaded fasteners



Safety Instructions

The following instructions are furnished as general guidelines for use of your pneumatic tool. They cannot comprehensively cover all possible or conceivable uses of the subject tool. For additional information on the safe use of air tools, we advise you to obtain a copy of ANSI B186.1 Safety Code for Portable Air Tools, available from the following source:

American National Standards Institute, Inc.
11 West 42nd Street
New York, NY 10036.

The use of the word "shall" in the following instructions, indicates that adherence to the particular requirement is necessary to conform to ANSI B186.1.

Tool Application and Usage

Portable tools shall be used only for the purposes intended in their design and within the capacity for which they were intended and rated. It shall be the tool owner's and/or employer's responsibility to instruct each operator in the safe use of the tool. Tools shall not be used without guards and safety

devices as furnished by the manufacturer. Where an air tool is modified or altered, the modifier shall provide the safeguards to enable it to be safely used in the operations intended and to comply with any applicable provisions as contained in ANSI B186.1.

Tool Installation

Pressure regulators shall be used to limit air pressure to the rated pressure where the supply pressure exceeds the tool's rated pressure. Air hoses and lines shall be relieved of compressed air before being disconnected or disjointed, unless there is automatic valve closing protection at the joint being separated. Synthetic lubricants which can cause deterioration of elastomer seals shall not be used in air systems of air tools.

Tool Maintenance

It shall be the tool owner's and/or employer's responsibility to assure that tools are maintained in a safe operating condition. Tool maintenance and repair shall be performed by authorized, trained, competent personnel. Tools shall be disconnected from their compressed air supply before repairs are attempted. Repairs shall be consistent with the manufacturer's recommended procedures. Tool, hoses and fittings shall be replaced if unsuitable for safe operation. It shall be the tool owner's and/or employer's responsibility to keep required rating markings and warnings on the tool in legible condition.



Universal Tool
A Division of Florida Pneumatic Manufacturing Corporation
851 Jupiter Park Lane, Jupiter, Florida 33458
Toll Free 1-800-327-9403

Read these instructions carefully before attempting to install, operate or service this Florida Pneumatic product. Failure to comply with the instructions could result in personal injury and/or property damage! Retain these instructions for future reference.

FPMC

Specifications

Horsepower	1 H P
Max Wheel Size	4" Type 1
Spindle size.....	3/8"-24
Free speed	1,600 RPM
Weight.....	3.1 lbs.
Length.....	12"
Average air consumption.....	4 CFM
Recommended hose size.....	3/8" I.D.
Air inlet.....	1/2" NPT
Maximum air pressure.....	90 psi

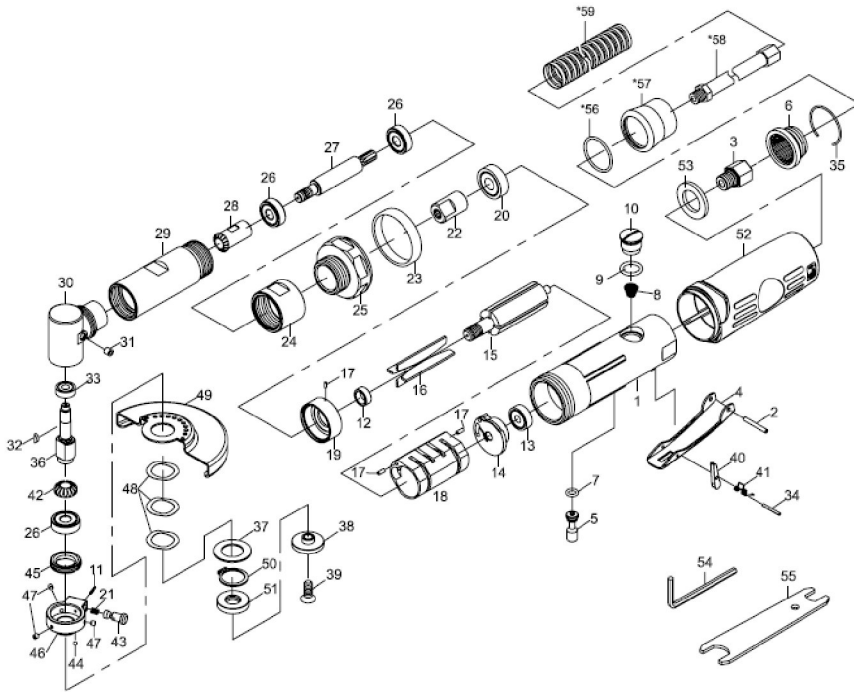
Parts Breakdown for UT8748

Replacement Parts for UT8748

REF.	PART #	DESCRIPTION	QTY
1	95K-3051B01	MOTOR HOUSING	1
2	930102	SPRING PIN(3X24L)	1
3	970628	AIR INLET	1
4	9961104	THROTTLE LEVER	1
5	9961105	VALVE SHAFT	1
6	970629	EXHAUST DIFFUSER	1
7	970107	O-RING(4.8X1.9)	1
8	951208	VALVE SPRING	1
9	970123	O-RING(11.8X2.4)	1
10	951-3011A10	PLUG	1
11	972902	SPRING PIN (2x10)	1
12	95K-3011B11	ROTOR BUSHING	1
13	9030113	BALL BEARING(626ZZ)	1
14	95K-3011B14	REAR END PLATE	1
15	95K-3011B15	ROTOR	1
16	95K-3011B16	ROTOR BLADE	4
17	972017	SPRING PIN (2.5*6L)	3
18	95K-3011B18	CYLINDER	1
19	95K-3011B19	FRONT END PLATE	1
20	9051220	BALL BEARING (6000ZZ)	1
21	95K-3011B08	SPRING	1
22	95K-3011B37	CONNECTER	1
23	95K-3011B12	DECORATION RING	1
24	95K-3011B20	CONNECTER NUT	1
25	95K-3011B35	CLAMP NUT	1
26	9030120	BALL BEARING (608ZZ)	3
27	95K-3011B38	ROLLER SHAFT	1
28	95K-3011B22	BEVEL GEAR	1
29	95K-3011B29	CONNECTER PIPE	1
30	9SM-56228	HEAD	1

REF.	PART #	DESCRIPTION	QTY
31	9SM-56237	OIL CAP	1
32	9SM-56232	KEY	1
33	9SM-56213	BALL BEARING (696ZZ)	1
34	951542	SPRING PIN(2X18L)	1
35	970630	RETAINER RING	1
36	95K-3011B28	SPINDLE	1
37	95K-3011B31	WASHER	1
38	95K-3011B27	FLANGE NUT	1
39	95K-3011B17	SCREW (M6x18L)	1
40	9962239	SAFETY BAR	1
41	922212	SPRING	1
42	95K-3011B23	BEVEL GEAR	1
43	95K-3011B24	STOP BUTTON	1
44	95K-3011B25	STEEL BALL (9/64")	1
45	9SM-56231	CLAMP NUT	1
46	95K-3011B30	COVER SEAT	1
47	95G-619737	SET SCREW (M4x4)	3
48	9WW20	WAVE WASHER (WW-20)	3
49	95L-3011B34	DISC COVER	1
50	9STW20	RETAINER RING (STW-20)	1
51	95K-3011B21	FLANGE	1
52	9512253	RUBBER GRIP	1
53	9961250	MUFFLER	1
54	910014S	HEX. KEY WRENCH (4MM)	1
55	952227	SPANNER (11MM, 17MM)	1
*56	970144	O-RING (25.07x2.62)	1
*57	970143	CLAMP	1
*58	951239	HOSE	1
*59	952238-1	EXHAUST HOSE	1

Limited Warranty

Universal Tool warrants its tools to be free from defects in material and workmanship for one year from the date of purchase. This warranty does not apply to tools which have been abused, misused, modified or repaired by someone other than Universal Tool or its authorized service centers. If a Universal Tool proves defective in material of workmanship within one year after purchase, return it to any authorized service center or to Universal Tool, freight prepaid. Please enclose your name, address and adequate proof of purchase date with a brief description of the defect. Universal Tool will, at its option, repair or replace defective tools, free of charge. Repairs or replacements are warranted as described above for the remainder of the warranty period. Universal Tool's sole liability and your exclusive remedy under this warranty is limited to repair or replacement of the defective tool. There are no other warranties expressed or implied and Universal Tool shall not be liable for incidental, consequential or special damages, or any other damages, costs or expense of repair or replacement as described above.