

PLEASE READ AND FOLLOW ALL WARNINGS

Universal Tool

UT8729-18

Angle Die Grinder

Read Operating Instructions

Always become familiar with all the instructions and warnings before operating any power tool.

Always Wear Approved Eye Protection

Impact resistant eye protection should meet or exceed the standards as set forth in the United States ANSI Z87.1, Occupational and Educational Eye and Face Protection. Look for the marking Z87.1 on your eye protection to insure that it is an approved style. For further information, ANSI Z87.1, Occupational and Educational Eye and Face Protection, is available from the American National Standards Institute, Inc., 11 West 42nd Street, New York, NY 10036.

Hearing Protection is Recommended

Hearing protection should be used when the noise level exposure equals or exceeds an 8 hour time-weighted average sound level of 85 dBA. Process noise, reflective surfaces, other tools being operated nearby, all add to the noise level present in your work area. If you are unable to determine your noise level exposure, we recommend the use of hearing protection.

Avoid Prolonged Exposure to Vibration

Tools can vibrate during use. Prolonged exposure to vibration or very repetitive hand and arm movements, can cause injury. Stop using any tool if discomfort, tingling feeling or pain occurs. You should consult your physician before resuming use of the tool.

90 PSIG Maximum

This tool is designed to operate at

an air pressure of 90 pounds per square inch gauge pressure (90 PSIG) maximum, at the tool. Use of higher air pressure can, and may cause injury. Also, the use of higher air pressure places the internal components under loads and stresses they were not designed for, causing premature failure. The air supply should be clean and dry, preferably lubricated. For best results, drain the moisture from your compressor daily.

WARNING

Always use accessories with an RPM rating that meets or exceeds the tool RPM rating.

WARNING:

Some dust created by power sanding, sawing, grinding, drilling, and other construction activities contains chemicals known to cause cancer, birth defects or reproductive harm. Some examples of these chemicals are:

- Lead from lead-based paints
- Crystalline silica from bricks, cement and other masonry products
- Arsenic and chromium from chemically treated lumber

Your risk from these exposures varies, depending on how often you do this type of work. To reduce your exposure to these chemicals, work in a well-ventilated area and work with approved safety equipment such as those dust masks that are specially designed to filter out microscopic particles.

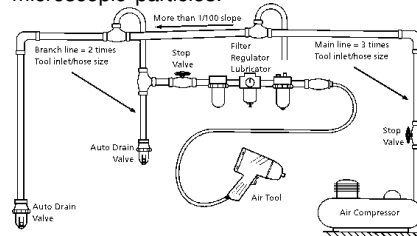

Description

UT8729-18 Angle Die Grinder features a 0.9 HP Motor for extra stall resistance; Safety lock-off throttle; Rear exhaust keeps work area clean from cuttings; Precision engineered for added reliability; ergonomic "Softouch" coating offers ultimate comfort and reduced vibration and spiral machined bevel and pinion gears for smooth operation and durability



UT8729-18

Safety Instructions

The following instructions are furnished as general guidelines for use of your pneumatic tool. They cannot comprehensively cover all possible or conceivable uses of the subject tool. For additional information on the safe use of air tools, we advise you to obtain a copy of ANSI B186.1 Safety Code for Portable Air Tools, available from the following source:

American National Standards Institute, Inc.
11 West 42nd Street
New York, NY 10036.

The use of the word "shall" in the following instructions, indicates that adherence to the particular requirement is necessary to conform to ANSI B186.1.

Tool Application and Usage

Portable tools shall be used only for the purposes intended in their design and within the capacity for which they were intended and rated. It shall be the tool owner's and/or employer's responsibility to instruct each operator in the safe use of the tool. Tools shall not be used without guards and safety

devices as furnished by the manufacturer. Where an air tool is modified or altered, the modifier shall provide the safeguards to enable it to be safely used in the operations intended and to comply with any applicable provisions as contained in ANSI B186.1.

Tool Installation

Pressure regulators shall be used to limit air pressure to the rated pressure where the supply pressure exceeds the tool's rated pressure. Air hoses and lines shall be relieved of compressed air before being disconnected or disjoined, unless there is automatic valve closing protection at the joint being separated. Synthetic lubricants which can cause deterioration of elastomer seals shall not be used in air systems of air tools.

Tool Maintenance

It shall be the tool owner's and/or employer's responsibility to assure that tools are maintained in a safe operating condition. Tool maintenance and repair shall be performed by authorized, trained, competent personnel. Tools shall be disconnected from their compressed air supply before repairs are attempted. Repairs shall be consistent with the manufacturer's recommended procedures. Tool, hoses and fittings shall be replaced if unsuitable for safe operation. It shall be the tool owner's and/or employer's responsibility to keep required rating markings and warnings on the tool in legible condition.

Universal Tool Manufacturing Corporation
851 Jupiter Park Lane, Jupiter, Florida 33458
Toll Free 1-800-327-9403

Read these instructions carefully before attempting to install, operate or service this Universal Tool product. Failure to comply with the instructions could result in personal injury and/or property damage! Retain these instructions for future reference.

FPMC

Motor.....	0.7
Max.Wheel Size.....	2"
Free speed	18,000 RPM
Weight.....	1.6 lbs.
Length.....	7.40"
Rec. Pressure.....	90 psi-6.2 bar
Recommended hose size.....	3/8" I.D.
Air inlet.....	1/4" NPT
Avg. Air Cons.....	5.5 CFM

Parts Breakdown for UT8729-18

Note: always use accessories with an RPM rating that meets or exceeds the tool RPM rating. Always examine accessories before mounting for chips, cracks, or signs of damage. Never use mounted points or other accessories that have been dropped or exposed to; water, solvent, or extreme temperature changes. It is a good practice to operate the tool in a protected enclosure for one minute after mounting any accessory.

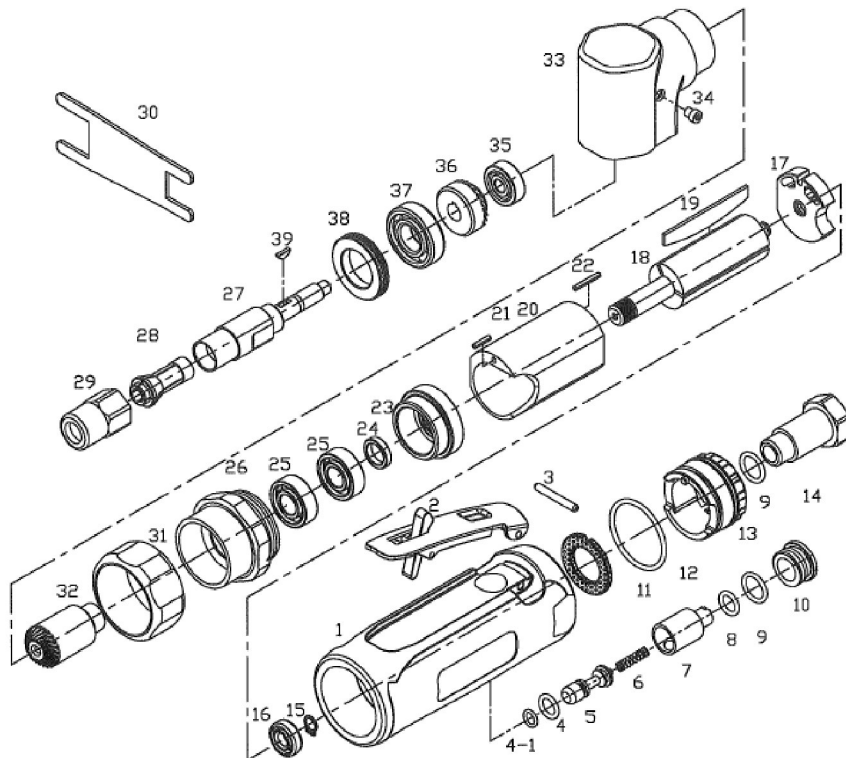

Ref.	FP Part No.	Description	Qty
1	9872801	MOTOR HOUSING	1
2	9872802B-18	THROTTLE LEVER ASSEMBLY W/LASER ETCHED	1
3	9308003	THROTTLE LEVER PIN	1
4	9308004	THROTTLE VALVE O-RING	1
4-1	9308004-1	THROTTLE VALVE O-RING	1
5	9872805	THROTTLE VALVE ASSEMBLY	1
6	9872806	THROTTLE VALVE SPRING	1
7	9872807	AIR REGULATOR	1
8	9OR-1898	AIR REGULATOR O-RING	2
9	9OR7718	VALVE CAP O-RING	1
10	9308010	THROTTLE VALVE CAP	1
11	9872811	DEFLECTOR SILENCER	1
12	9633811	DEFLECTOR O-RING	1
13	9872813	DEFLECTOR	1
14	9872814	AIR INLET	1
15	9389516	RETAINER	1
16	9R4ZZ	BALL BEARING	1
17	9872817	END PLATE-REAR	1
18	9872918	ROTOR	1
19	9389517	ROTOR BLADE	3
20	9389521N	CYLINDER	1
21	9389521A	CYLINDER PIN 1	1
22	9872822	CYLINDER PIN 2	1
23	9872923	FRONT PLATE	1
24	9389735	SPACER	3
25	9BR6ZZ	BALL BEARING	2
26	9872926	ANGLE HEAD CLAMP	1
27	9872927	ANGLE COLLET BODY	1
28	9308024	1/4" COLLET	1
29	9872829	COLLET NUT	1
30	9308026	COLLET WRENCH	2
31	9872931	ANGLE HEAD NUT	1
32	9872932-18	GEAR SET - 1	1
33	9872933	ANGLE HEAD - HEXAGON	1
34	9872934	GREASE FITTING	1
35	9B626ZZ	BALL BEARING	1
36	9872936-18	GEAR SET - 2	1
37	9R8ZZ	BALL BEARING	1
38	9872938	BEARING RETAINER	1
39	9872939	WOODRUFF KEY	1

Limited Warranty

Universal Tool warrants its tools to be free from defects in material and workmanship for one year from the date of purchase. This warranty does not apply to tools which have been abused, misused, modified or repaired by someone other than Universal Tool or its authorized service centers. If a Universal Tool proves defective in material of workmanship within one year after purchase, return it to any authorized service center or to Universal Tool, freight prepaid. Please enclose your name, address and adequate proof of purchase date with a brief description of the defect. Universal Tool will, at its option, repair or replace defective tools, free of charge. Repairs or replacements are warranted as described above for the remainder of the warranty period. Universal Tool's sole liability and your exclusive remedy under this warranty is limited to repair or replacement of the defective tool. There are no other warranties expressed or implied and Universal Tool shall not be liable for incidental, consequential or special damages, or any other damages, costs or expense of repair or replacement as described above.