

PLEASE READ AND FOLLOW ALL WARNINGS



UT8703-1

20 MM BELT SANDER

Read Operating Instructions

Always become familiar with all the instructions and warnings before operating any power tool.

Always Wear Approved Eye Protection

Impact resistant eye protection should meet or exceed the standards as set forth in the United States ANSI Z87.1, Occupational and Educational Eye and Face Protection. Look for the marking Z87.1 on your eye protection to insure that it is an approved style. For further information, ANSI Z87.1, Occupational and Educational Eye and Face Protection, is available from the American National Standards Institute, Inc., 11 West 42nd Street, New York, NY 10036.

Hearing Protection is Recommended

Hearing protection should be used when the noise level exposure equals or exceeds an 8 hour time-weighted average sound level of 85 dBA. Process noise, reflective surfaces, other tools being operated nearby, all add to the noise level present in your work area. If you are unable to determine your noise level exposure, we recommend the use of hearing protection.

Avoid Prolonged Exposure to Vibration

Tools can vibrate during use. Prolonged exposure to vibration or very repetitive hand and arm movements, can cause injury. Stop using any tool if discomfort, tingling feeling or pain occurs. You should consult your physician before resuming use of the tool.

90 PSIG Maximum

This tool is designed to operate at

an air pressure of 90 pounds per square inch gauge pressure (90 PSIG) maximum, at the tool. Use of higher air pressure can, and may cause injury. Also, the use of higher air pressure places the internal components under loads and stresses they were not designed for, causing premature failure. The air supply should be clean and dry, preferably lubricated. For best results, drain the moisture from your compressor daily.

WARNING:

Some dust created by power sanding, sawing, grinding, drilling, and other construction activities contains chemicals known to cause cancer, birth defects or reproductive harm. Some examples of these chemicals are:

- Lead from lead-based paints
- Crystalline silica from bricks, cement and other masonry products
- Arsenic and chromium from chemically treated lumber

Your risk from these exposures varies, depending on how often you do this type of work. To reduce your exposure to these chemicals, work in a well-ventilated area and work with approved safety equipment such as those dust masks that are specially designed to filter out microscopic particles.

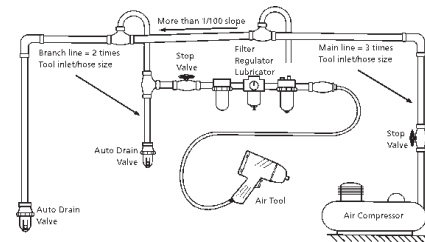

Description

Universal Tool Multi-Angle Belt Sander is designed for hard-to-reach corners, contours, and hard-to-finish surfaces. Used to sand, grind, and finish aluminum, steel, cast iron, plywood, plastic and stone. **Please note : Multi-Angle Belt Sanders are not designed for sanding directly on the front roller.**



PL0368

devices as furnished by the manufacturer. Where an air tool is modified or altered, the modifier shall provide the safeguards to enable it to be safely used in the operations intended and to comply with any applicable provisions as contained in ANSI B186.1.

Safety Instructions

The following instructions are furnished as general guidelines for use of your pneumatic tool. They cannot comprehensively cover all possible or conceivable uses of the subject tool. For additional information on the safe use of air tools, we advise you to obtain a copy of ANSI B186.1 Safety Code for Portable Air Tools, available from the following source:

American National Standards Institute, Inc.
11 West 42nd Street
New York, NY 10036.

The use of the word "shall" in the following instructions, indicates that adherence to the particular requirement is necessary to conform to ANSI B186.1.

Tool Application and Usage

Portable tools shall be used only for the purposes intended in their design and within the capacity for which they were intended and rated. It shall be the tool owner's and/or employer's responsibility to instruct each operator in the safe use of the tool. Tools shall not be used without guards and safety

Tool Installation

Pressure regulators shall be used to limit air pressure to the rated pressure where the supply pressure exceeds the tool's rated pressure. Air hoses and lines shall be relieved of compressed air before being disconnected or disjoined, unless there is automatic valve closing protection at the joint being separated. Synthetic lubricants which can cause deterioration of elastomer seals shall not be used in air systems of air tools.

Tool Maintenance

It shall be the tool owner's and/or employer's responsibility to assure that tools are maintained in a safe operating condition. Tool maintenance and repair shall be performed by authorized, trained, competent personnel. Tools shall be disconnected from their compressed air supply before repairs are attempted. Repairs shall be consistent with the manufacturer's recommended procedures. Tool, hoses and fittings shall be replaced if unsuitable for safe operation. It shall be the tool owner's and/or employer's responsibility to keep required rating markings and warnings on the tool in legible condition.

Universal Tool
A Division of Florida Pneumatic Manufacturing Corporation
851 Jupiter Park Lane, Jupiter, Florida 33458
Toll Free 1-800-327-9403

Read these instructions carefully before attempting to install, operate or service this Florida Pneumatic product. Failure to comply with the instructions could result in personal injury and/or property damage! Retain these instructions for future reference.

FPMC

Belt width 20mm
 Belt size..... 3/4 x 20½"
 Speed..... 16,000 RPM
 Weight..... 3 lbs.
 Overall length..... 14½"
 Average air consumption..... 18 CFM
 Air inlet..... 1/4" NPT
 Recommended hose size..... 3/8" I.D.
 Maximum air pressure..... 90 PSI

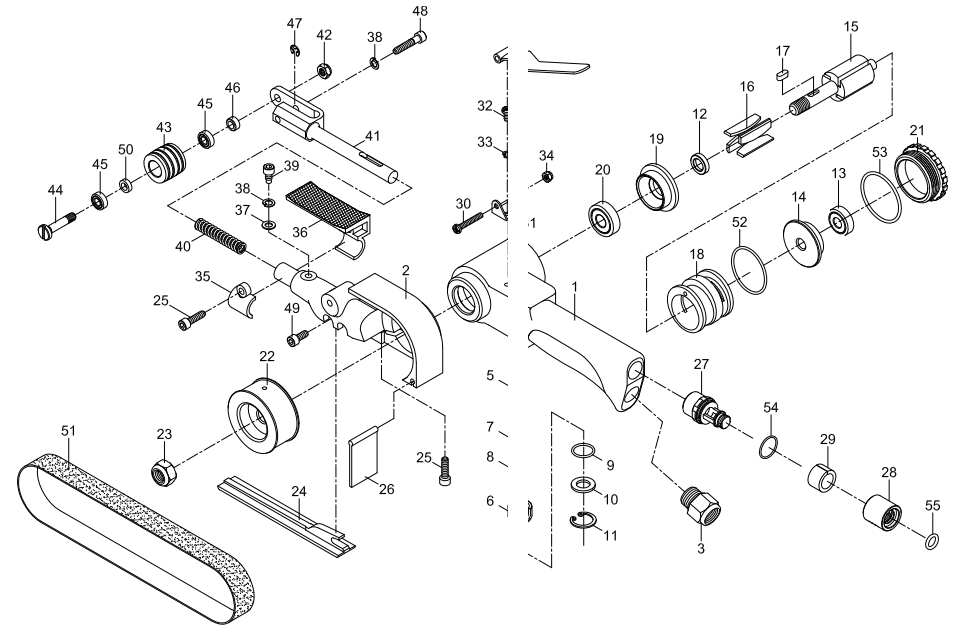
SANDING BELTS FOR THE UT8703

3/4"x 20½" 60 grit belts (10) 802060A
 3/4"x 20½" 80 grit belts (10) 802080A
 3/4"x 20½" 120 grit belts (10) 802120A

Limited Warranty

Universal Tool warrants its tools to be free from defects in material and workmanship for one year from the date of purchase. This warranty does not apply to tools which have been abused, misused, modified or repaired by someone other than Universal Tool or its authorized service centers. If a Universal Tool proves defective in material of workmanship within one year after purchase, return it to any authorized service center or to Universal Tool, freight prepaid. Please enclose your name, address and adequate proof of purchase date with a brief description of the defect. Universal Tool will, at its option, repair or replace defective tools, free of charge. Repairs or replacements are warranted as described above for the remainder of the warranty period. Universal Tool's sole liability and your exclusive remedy under this warranty is limited to repair or replacement of the defective tool. There are no other warranties expressed or implied and Universal Tool shall not be liable for incidental, consequential or special damages, or any other damages, costs or expense of repair or replacement as described above.

Index		
No.	Parts No.	Description
1	95M62001	Housing
2	95M62002	Guard Body
3	95M62003	Air Inlet
4	95M62004	Lever
5	95M62005	Valve Stem
6	95M62006	Adjust Valve
7	930107	O-Ring
8	95M62008	Spring
9	95M62009	O-Ring
10	95M62010	Spacer
11	95M62011	Retaining Ring
12	95M62012	Distance Collar
13	9030120	Ball Bearing
14	95M62014	Rear End Plate
15	95M62015	Rotor
16	95M62016	Rotor Blade (4)
17	95M62017	Key
18	95M62018	Cylinder
19	95M62019	Front End Plate
20	9051220	Ball Bearing
21	95M62021	Cap
22	95M62022	Drive Pulley
23	95M62023	Nut
24	95M62024	Flat Shoe
25	95M62025	Bolt (2)
26	95M62026	Dust Cover
27	966-6133C23	Exhaust Shaft
28	966-6133C24	Exhaust Sleeve

Index		
No.	Parts No.	Description
29	966-6133C25	Muffler
30	95M62030	Screw
31	95M62031	Lever Support
32	95M62032	Screw (2)
33	940147	Spring Washer (2)
34	95M62034	Nut
35	95M62035	Bushing
36	95M62036	Finger Pad
37	95M62037	Washer
38	940344	Spring Washer
39	95M62039	Screw
40	95M62040	Spring
41	95M62041	Arm
42	95M63042	Nut
43	95M62043	Idle Pulley
44	95M62044	Shaft
45	9062045	Ball Bearing (2)
46	95M62046	Spacer
47	95M62047	Retaining Ring
48	95M62048	Bolt
49	95M62049	Bolt
50	95M62050	Spacer
51	95M62060	Grinding Belt
52	90R02607108	O-Ring
53	9812E12	O-Ring
54	982209	O-Ring
55	976010	O-Ring