



PLEASE READ AND FOLLOW ALL WARNINGS



Universal Tool

UT8617 / UT8617K

MINI CHIPPING HAMMER / SCRIBE

Read Operating Instructions
Always become familiar with all the instructions and warnings before operating any power tool.



Always Wear Approved Eye Protection
Impact resistant eye protection should meet or exceed the standards as set forth in the United States ANSI Z87.1, Occupational and Educational Eye and Face Protection. Look for the marking Z87.1 on your eye protection to insure that it is an approved style. For further information, ANSI Z87.1, Occupational and Educational Eye and Face Protection, is available from the American National Standards Institute, Inc., 11 West 42nd Street, New York, NY 10036.



Hearing Protection is Recommended
Hearing protection should be used when the noise level exposure equals or exceeds an 8 hour time-weighted average sound level of 85 dBA. Process noise, reflective surfaces, other tools being operated nearby, all add to the noise level present in your work area. If you are unable to determine your noise level exposure, we recommend the use of hearing protection.



Avoid Prolonged Exposure to Vibration
Tools can vibrate during use. Prolonged exposure to vibration or very repetitive hand and arm movements, can cause injury. Stop using any tool if discomfort, tingling feeling or pain occurs. You should consult your physician before resuming use of the tool.
60 PSIG Maximum
This tool is designed to operate at

an air pressure of 60 pounds per square inch gauge pressure (60 PSIG) maximum, at the tool. Use of higher air pressure can, and may cause injury. Also, the use of higher air pressure places the internal components under loads and stresses they were not designed for, causing premature failure. The air supply should be clean and dry, preferably lubricated. For best results, drain the moisture from your compressor daily.

WARNING:

Some dust created by power sanding, sawing, grinding, drilling, and other construction activities contains chemicals known to cause cancer, birth defects or reproductive harm. Some examples of these chemicals are:

- Lead from lead-based paints
- Crystalline silica from bricks, cement and other masonry products
- Arsenic and chromium from chemically treated lumber

Your risk from these exposures varies, depending on how often you do this type of work. To reduce your exposure to these chemicals, work in a well-ventilated area and work with approved safety equipment such as those dust masks that are specially designed to filter out microscopic particles.

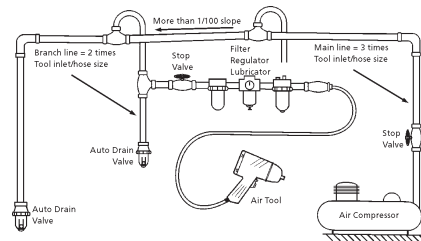

Description

Universal Tool MINI CHIPPING HAMMER / SCRIBE is designed to permanently mark hard materials, including tools, parts and assemblies made of non-ferrous metals, hardened tool steel, glass, ceramic and plastic.



Safety Instructions

The following instructions are furnished as general guidelines for use of your pneumatic tool. They cannot comprehensively cover all possible or conceivable uses of the subject tool. For additional information on the safe use of air tools, we advise you to obtain a copy of ANSI B186.1 Safety Code for Portable Air Tools, available from the following source:

American National Standards Institute, Inc.
11 West 42nd Street
New York, NY 10036.

The use of the word "shall" in the following instructions, indicates that adherence to the particular requirement is necessary to conform to ANSI B186.1.

Tool Application and Usage
Portable tools shall be used only for the purposes intended in their design and within the capacity for which they were intended and rated. It shall be the tool owner's and/or employer's responsibility to instruct each operator in the safe use of the tool. Tools shall not be used without guards and safety

devices as furnished by the manufacturer. Where an air tool is modified or altered, the modifier shall provide the safeguards to enable it to be safely used in the operations intended and to comply with any applicable provisions as contained in ANSI B186.1.

Tool Installation

Pressure regulators shall be used to limit air pressure to the rated pressure where the supply pressure exceeds the tool's rated pressure. Air hoses and lines shall be relieved of compressed air before being disconnected or disjointed, unless there is automatic valve closing protection at the joint being separated. Synthetic lubricants which can cause deterioration of elastomer seals shall not be used in air systems of air tools.

Tool Maintenance

It shall be the tool owner's and/or employer's responsibility to assure that tools are maintained in a safe operating condition. Tool maintenance and repair shall be performed by authorized, trained, competent personnel. Tools shall be disconnected from their compressed air supply before repairs are attempted. Repairs shall be consistent with the manufacturer's recommended procedures. Tool, hoses and fittings shall be replaced if unsuitable for safe operation. It shall be the tool owner's and/or employer's responsibility to keep required rating markings and warnings on the tool in legible condition.



Universal Tool

A Division of Florida Pneumatic Manufacturing Corporation
851 Jupiter Park Lane, Jupiter, Florida 33458
Toll Free 1-800-327-9403

Read these instructions carefully before attempting to install, operate or service this Florida Pneumatic product. Failure to comply with the instructions could result in personal injury and/or property damage! Retain these instructions for future reference.



Strokes per min.....13,500
 Weight.....4.6oz
 Length.....4.8"
 Maximum operating pressure.....60PSI

Parts Breakdown for UT8617 / UT8617K
Replacement Parts for UT8617 / UT8617K

Ref.	Description	Part #	Ref.	Description	Part #
1	Filter Body	8901543	14	O-ring	8901555
2	Filter	8901544	15	Pen Chisel	8901556
3	Wip Hose	8901545	16	Chisel Joint	8901557
4	Valve Body	8901546	17	Housing	8901558
5	Roll Pin	8901547	18	Ring Ball Lock	8901559
6	O-Ring	8901548	19	Chisel Guide	8901560
7	E-Ring	8901549	20	Steel Ball	81004968
8	Cylinder Pin	8900032	21	O-Ring	8901561
9	O-Ring (3)	8901550	22	Steel Ball	81005164
10	Regulator Dial	8901551	23	Chisel A	8901562
11	O-Ring (3)	8904552	24	Chisel B	8901563
12	Piston	8901553	25	Chisel C	8901564
13	Cylinder	8901554			

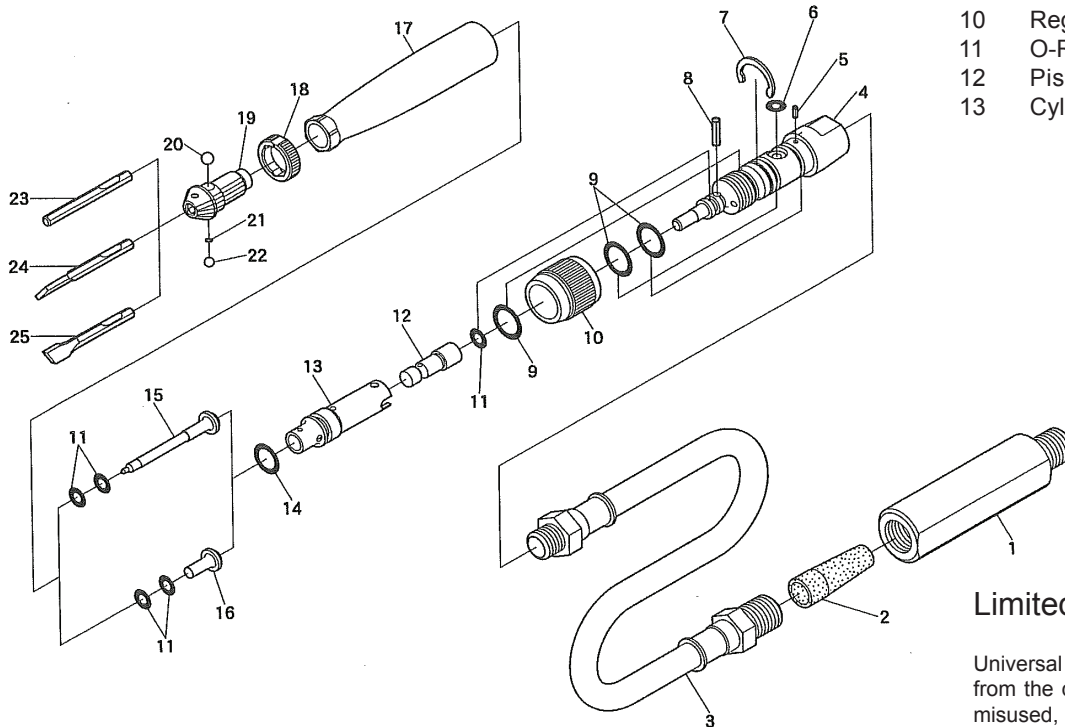
Limited W arranty

Universal Tool warrants its tools to be free from defects in material and workmanship for one year from the date of purchase. This warranty does not apply to tools which have been abused, misused, modified or repaired by someone other than Universal Tool or its authorized service centers. If a Universal Tool proves defective in material or workmanship within one year after purchase, return it to any authorized service center or to Universal Tool, freight prepaid. Please enclose your name, address and adequate proof of purchase date with a brief description of the defect. Universal Tool will, at its option, repair or replace defective tools, free of charge. Repairs or replacements are warranted as described above for the remainder of the warranty period. Universal Tool's sole liability and your exclusive remedy under this warranty is limited to repair or replacement of the defective tool. There are no other warranties expressed or implied and Universal Tool shall not be liable for incidental, consequential or special damages, or any other damages, costs or expense of repair or replacement as described above.



UT8617 and UT8617K SCRIBE/ENGRAVING TOOL and KIT

Chisel Installation and Removal

To install or remove chisels # 23, 24 or 25:

1. Disconnect the tool from the air supply.
2. Remove the housing (# 17) by turning counter clockwise with an open end wrench.
3. Remove or install the desired chisel # 23, 24 or 25 from/into the open nose at the front of the housing (#17).
4. Reassemble the housing (#17) by tightening clockwise with an open end wrench.
5. Check for proper operation.

To remove or install the stylus (Pen Chisel) # 15:

1. Disconnect the tool from the air supply.
2. Using an adjustable open end wrench turn the spring ball lock (# 18) counter clockwise to its unlocked position.
3. Remove or install pen chisel (# 15) by pulling out off/or pushing into the open nose at the front of the tool.
4. Using an adjustable open end wrench turn the spring ball (#18) clockwise to its locked position
5. Check for proper operation.

