

PLEASE READ AND FOLLOW ALL WARNINGS



UT2147

1/2" Pistol Impact

Read Operating Instructions

Always become familiar with all the instructions and warnings before operating any power tool.

Always Wear Approved Eye Protection

Impact resistant eye protection should meet or exceed the standards as set forth in the United States ANSI Z87.1, Occupational and Educational Eye and Face Protection. Look for the marking Z87.1 on your eye protection to insure that it is an approved style. For further information, ANSI Z87.1, Occupational and Educational Eye and Face Protection, is available from the American National Standards Institute, Inc., 11 West 42nd Street, New York, NY 10036.

Hearing Protection is Recommended

Hearing protection should be used when the noise level exposure equals or exceeds an 8 hour time-weighted average sound level of 85 dBA. Process noise, reflective surfaces, other tools being operated nearby, all add to the noise level present in your work area. If you are unable to determine your noise level exposure, we recommend the use of hearing protection.

Avoid Prolonged Exposure to Vibration

Tools can vibrate during use. Prolonged exposure to vibration or very repetitive hand and arm movements, can cause injury. Stop using any tool if discomfort, tingling feeling or pain occurs. You should consult your physician before resuming use of the tool.

90 PSIG Maximum

This tool is designed to operate at

an air pressure of 90 pounds per square inch gauge pressure (90 PSIG) maximum, at the tool. Use of higher air pressure can, and may cause injury. Also, the use of higher air pressure places the internal components under loads and stresses they were not designed for, causing premature failure. The air supply should be clean and dry, preferably lubricated. For best results, drain the moisture from your compressor daily.

WARNING:

Some dust created by power sanding, sawing, grinding, drilling, and other construction activities contains chemicals known to cause cancer, birth defects or reproductive harm. Some examples of these chemicals are:

- Lead from lead-based paints
- Crystalline silica from bricks, cement and other masonry products
- Arsenic and chromium from chemically treated lumber

Your risk from these exposures varies, depending on how often you do this type of work. To reduce your exposure to these chemicals, work in a well-ventilated area and work with approved safety equipment such as those dust masks that are specially designed to filter out microscopic particles.

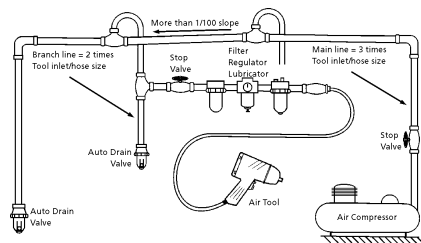

Description

Universal Tool 1/2" impact wrenches are designed for a wide variety of MRO and assembly applications. This tool features a built-in power regulator for convenient power output adjustment, front and rear housing protector and a ring type socket retainer for quick and easy socket changes.



devices as furnished by the manufacturer. Where an air tool is modified or altered, the modifier shall provide the safeguards to enable it to be safely used in the operations intended and to comply with any applicable provisions as contained in ANSI B186.1.

Safety Instructions

The following instructions are furnished as general guidelines for use of your pneumatic tool. They cannot comprehensively cover all possible or conceivable uses of the subject tool. For additional information on the safe use of air tools, we advise you to obtain a copy of ANSI B186.1 Safety Code for Portable Air Tools, available from the following source:

American National Standards Institute, Inc.
11 West 42nd Street
New York, NY 10036.

The use of the word "shall" in the following instructions, indicates that adherence to the particular requirement is necessary to conform to ANSI B186.1.

Tool Application and Usage

Portable tools shall be used only for the purposes intended in their design and within the capacity for which they were intended and rated. It shall be the tool owner's and/or employer's responsibility to instruct each operator in the safe use of the tool. Tools shall not be used without guards and safety

Tool Installation

Pressure regulators shall be used to limit air pressure to the rated pressure where the supply pressure exceeds the tool's rated pressure. Air hoses and lines shall be relieved of compressed air before being disconnected or disjoined, unless there is automatic valve closing protection at the joint being separated. Synthetic lubricants which can cause deterioration of elastomer seals shall not be used in air systems of air tools.

Tool Maintenance

It shall be the tool owner's and/or employer's responsibility to assure that tools are maintained in a safe operating condition. Tool maintenance and repair shall be performed by authorized, trained, competent personnel. Tools shall be disconnected from their compressed air supply before repairs are attempted. Repairs shall be consistent with the manufacturer's recommended procedures. Tool, hoses and fittings shall be replaced if unsuitable for safe operation. It shall be the tool owner's and/or employer's responsibility to keep required rating markings and warnings on the tool in legible condition.

Florida Pneumatic Manufacturing Corporation
851 Jupiter Park Lane, Jupiter, Florida 33458
Toll Free 1-800-327-9403

Read these instructions carefully before attempting to install, operate or service this Florida Pneumatic product. Failure to comply with the instructions could result in personal injury and/or property damage! Retain these instructions for future reference.

FPMC

Drive size.....	1/2"
Free speed (No Load).....	8,000 RPM
Impacts per minute.....	1,300 IPM
Maximum torque.....	500 ft.lbs.
Weight.....	5-1/2 lbs.
Overall length.....	7-1/2"
Average air consumption.....	3.5 CFM
Recommended hose size.....	3/8" I.D.
Air inlet.....	1/4" NPT
Maximum Air Pressure.....	90 PSI

Parts Breakdown for UT2147

USE ONLY IMPACT SOCKETS & ACCESSORIES

Sockets and accessories used shall be of the impact socket type. Always check sockets, retainers and drives regularly for wear or damage and replace whenever necessary

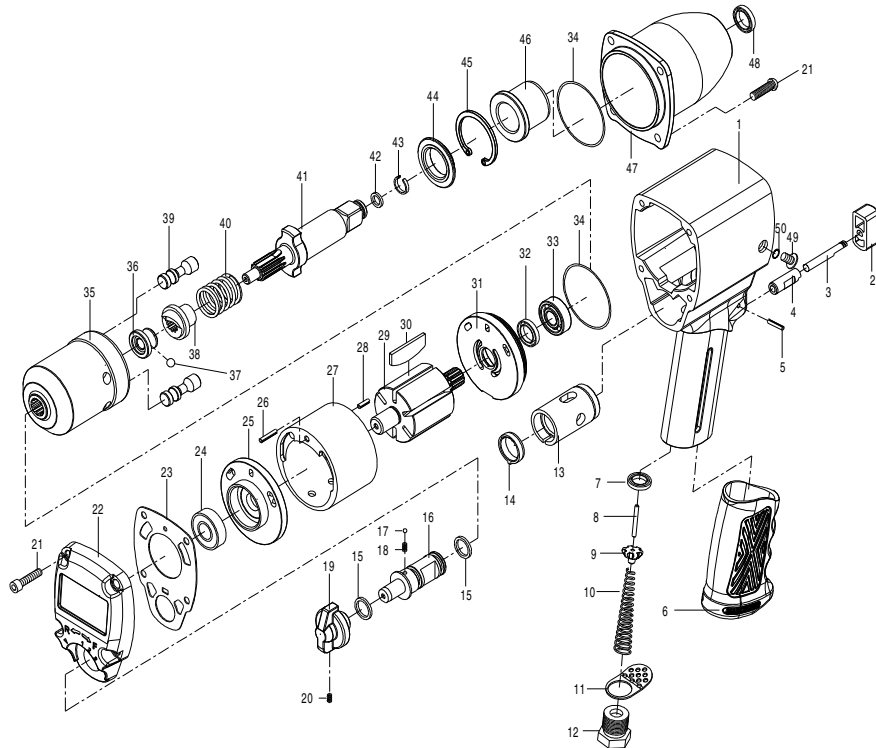

Replacement Parts for UT2147

Ref. Part #	Description	Qty	Ref. Part no	Description	Qty		
1	92560B01	Housing	1	26	9287226	Dowel Pin	1
2	9287204	Trigger	1	27	9287225	Cylinder	1
3	92560A03	Trigger Pin	1	28	9287224	Dowel Pin	1
4	9287206	Trigger Sleeve	1	29	9287223	Rotor	1
5	9287208	Spring Pin	1	30	9287222	Rotor Blade	6
6	9287215	Handle Grip	1	31	9287221	Front End Plate	1
7	9287209	Valve Seat	1	32	9287220	Oil Seal	1
8	9287210	Valve Stem	1	33	9287219	Ball Bearing	1
9	9287211	Throttle Valve	1	34	9287218	O-ring	2
10	9287212	Valve Spring	1	35	9287239	Hammer Cage	1
11	9287213	Exhaust Deflector	1	36	9287241	Drive Ball Seat	1
12	9287214	Air Inlet Bushing	1	37	9287240	Steel Ball	1
13	9287216	Reverse Bushing	1	38	9287242	Cam	1
14	9287217	Regulator Retainer	1	39	9287243	Hammer Pin	2
15	9287235	O-ring	2	40	9287244	Spring	1
16	9287236	Reverse Valve	1	41	9287245	Anvil	1
17	9287237	Steel Ball	1	42	9287246	O-ring	1
18	9287238	Spring	1	43	9287247	Socket Retainer	1
19	9287233	Reverse Switch	1	44	9287248	Washer	1
20	9287234	Screw	1	45	9287249	Retainer Ring	1
21	9287232	Cap Screw	8	46	9287230	Anvil Bushing	1
22	9287231	End Cap	1	47	9287207	Hammer Case	1
23	9287229	Gasket	1	48	9287203	Oil Seal	1
24	9287228	Ball Bearing	1	49	986009	Oil Plug	1
25	9287227	Rear end plate	1	50	921017	O-ring	1

Limited Warranty

Universal Tool warrants its tools to be free from defects in material and workmanship for one year from the date of purchase. This warranty does not apply to tools which have been abused, misused, modified or repaired by someone other than Universal Tool or its authorized service centers. If a Universal Tool proves defective in material of workmanship within one year after purchase, return it to any authorized service center or to Universal Tool, freight prepaid. Please enclose your name, address and adequate proof of purchase date with a brief description of the defect. Universal Tool will, at its option, repair or replace defective tools, free of charge. Repairs or replacements are warranted as described above for the remainder of the warranty period. Universal Tool's sole liability and your exclusive remedy under this warranty is limited to repair or replacement of the defective tool. There are no other warranties expressed or implied and Universal Tool shall not be liable for incidental, consequential or special damages, or any other damages, costs or expense of repair or replacement as described above.