



PLEASE READ AND FOLLOW ALL WARNINGS



**FLORIDA**  
PNEUMATIC

FP-2000 & FP-2100  
HIGH SPEED SANDER

Read Operating Instructions  
Always become familiar with all the instructions and warnings before operating any power tool.



**Always Wear Approved Eye Protection**  
Impact resistant eye protection should meet or exceed the standards as set forth in the United States ANSI Z87.1, Occupational and Educational Eye and Face Protection. Look for the marking Z87.1 on your eye protection to insure that it is an approved style. For further information, ANSI Z87.1, Occupational and Educational Eye and Face Protection, is available from the American National Standards Institute, Inc., 11 West 42nd Street, New York, NY 10036.



**Hearing Protection is Recommended**  
Hearing protection should be used when the noise level exposure equals or exceeds an 8 hour time-weighted average sound level of 85 dBA. Process noise, reflective surfaces, other tools being operated nearby, all add to the noise level present in your work area. If you are unable to determine your noise level exposure, we recommend the use of hearing protection.



**Avoid Prolonged Exposure to Vibration**  
Tools can vibrate during use. Prolonged exposure to vibration or very repetitive hand and arm movements, can cause injury. Stop using any tool if discomfort, tingling feeling or pain occurs. You should consult your physician before resuming use of the tool.



**90 PSIG Maximum**  
This tool is designed to operate at

An air pressure of 90 pounds per square inch gauge pressure (90 PSIG) maximum, at the tool. Use of higher air pressure can, and may cause injury. Also, the use of higher air pressure places the internal components under loads and stresses they were not designed for, causing premature failure. The air supply should be clean and dry, preferably lubricated. For best results, drain the moisture from your compressor daily.

**WARNING:**  
Some dust created by power sanding, sawing, grinding, drilling, and other construction activities contains chemicals known to cause cancer, birth defects or reproductive harm. Some examples of these chemicals are:

- Lead from lead-based paints
- Crystalline silica from bricks, cement and other masonry products
- Arsenic and chromium from chemically treated lumber

Your risk from these exposures varies, depending on how often you do this type of work. To reduce your exposure to these chemicals, work in a well-ventilated area and work with approved safety equipment such as those dust masks that are specially designed to filter out microscopic particles.

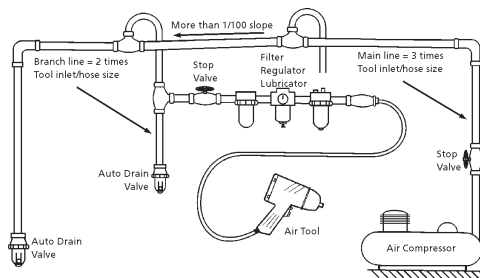

## Description

Florida Pneumatic high speed sander is ideal for feather edging and production sanding. This tool features a lightweight, impact resistant nylon handle and spring mounted trigger. Three backing discs are included in 3", 4 1/2" and 5 1/2" diameter sizes for added versatility. Made in U.S.A.



### Safety Instructions

The following instructions are furnished as general guidelines for use of your pneumatic tool. They cannot comprehensively cover all possible or conceivable uses of the subject tool. For additional information on the safe use of air tools, we advise you to obtain a copy of ANSI B186.1 Safety Code for Portable Air Tools, available from the following source:

American National Standards Institute, Inc.  
11 West 42nd Street  
New York, NY 10036.

The use of the word "shall" in the following instructions, indicates that adherence to the particular requirement is necessary to conform to ANSI B186.1.

**Tool Application and Usage**  
Portable tools shall be used only for the purposes intended in their design and within the capacity for which they were intended and rated. It shall be the tool owner's and/or employer's responsibility to instruct each operator in the safe use of the tool. Tools shall not be used without guards and safety

devices as furnished by the manufacturer. Where an air tool is modified or altered, the modifier shall provide the safeguards to enable it to be safely used in the operations intended and to comply with any applicable provisions as contained in ANSI B186.1.

### Tool Installation

Pressure regulators shall be used to limit air pressure to the rated pressure where the supply pressure exceeds the tool's rated pressure. Air hoses and lines shall be relieved of compressed air before being disconnected or disjoined, unless there is automatic valve closing protection at the joint being separated. Synthetic lubricants which can cause deterioration of elastomer seals shall not be used in air systems of air tools.

### Tool Maintenance

It shall be the tool owner's and/or employer's responsibility to assure that tools are maintained in a safe operating condition. Tool maintenance and repair shall be performed by authorized, trained, competent personnel. Tools shall be disconnected from their compressed air supply before repairs are attempted. Repairs shall be consistent with the manufacturer's recommended procedures. Tool, hoses and fittings shall be replaced if unsuitable for safe operation. It shall be the tool owner's and/or employer's responsibility to keep required rating markings and warnings on the tool in legible condition.

Read these instructions carefully before attempting to install, operate or service this Florida Pneumatic product. Failure to comply with the instructions could result in personal injury and/or property damage! Retain these instructions for future reference.

Florida Pneumatic Air Tools  
A Division of Florida Pneumatic Manufacturing Corporation  
851 Jupiter Park Lane, Jupiter, Florida 33458  
(561) 744-9500 • Fax (561) 575-9134 • Toll Free 1-800-327-9403

**FPMC**

PL-0103

## Specifications

Free speed.....	20,000 RPM
Backing disc size(s).....	3", 4 1/2", 5 1/2"
Center hole size.....	7/8"
Length.....	7 3/4"
Weight.....	1 3/4 lbs.
Air inlet.....	1/4"NPT
Recommended hose size.....	3/8" I.D.
Average air consumption.....	4 CFM
Maximum operating pressure.....	.90psi

## Parts Breakdown for FP-2000

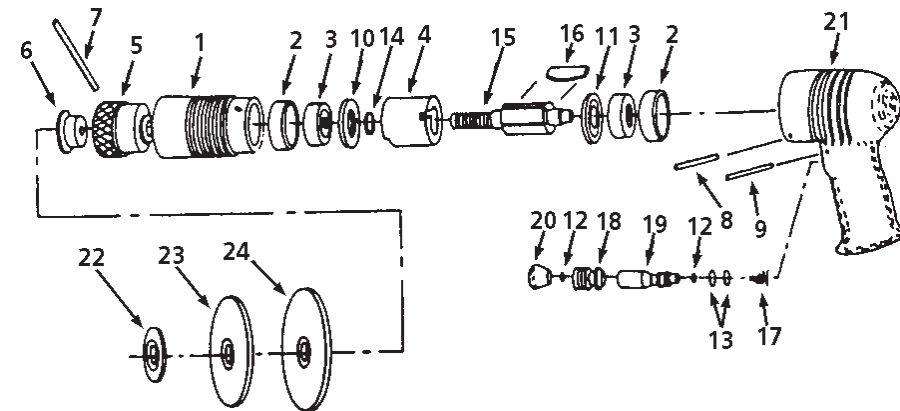

## Replacement Parts for

Ref.	Description	Part #	Ref.	Description	Part #
1	* Barrel	101020	16*	Vane (4)	116210
2	* Bearing carrier (2)	102010	17	Spring	118020
3	* Bearing (2)	102020	18	Trigger body	120120
4	* Cage	103010	19	Trigger stem	120220
5	Hub	107020	20	Trigger button	120520
6	• Pad nut	110010	21	Handle Assembly	* 262360
7	Holding rod	110210	25	3" fiber pad	5403
8	Barrel retaining pin	111220	26	4 1/2" fiber pad	5404
9	T/V retaining pin	111230	27	5 1/2" fiber pad	5405
10	* Front end plate	113010	28	Auxiliary handle	5814
11	* Rear end plate	113120	(*)	Motor unit complete	425080
12	O-ring (2)	115120	(•)	Tune up kit	200 Kit
13	O-ring (2)	115160	(Δ)	Not shown.	
14	* Stop ring	115210			
15	* Rotor	116020			

## FP-2100

Includes inline regulator # 5711

\* 262360 Handle Assembly Includes:

- 120120 Trigger valve body
- 120220 Trigger valve stem
- 120520 Trigger button
- 118020 Spring
- 111230 Retaining pin
- 115120 O-ring (2)
- 115160 O-ring (2)

## Florida Pneumatic's Limited Warranty

Florida Pneumatic warrants their tools to be free from defects in material and workmanship for one year from the date of purchase. This warranty does not apply to tools which have been abused, misused, modified or repaired by someone other than Florida Pneumatic or their authorized service centers. If a Florida Pneumatic tool proves defective in material or workmanship within one year after purchase, return it to any authorized service center or Florida Pneumatic freight prepaid. Please enclose your name, address and adequate proof of purchase and a short description of the defect. Florida Pneumatic will, at their option, repair or replace defective tools, free of charge. Repairs or replacements are warranted as described above for the remainder of the original warranty period. Florida Pneumatic's sole liability and your exclusive remedy under this warranty is limited to repair or replacement of the defective tool. There are no other warranties expressed or implied and Florida Pneumatic shall not be liable for incidental, consequential or special damages, or any other damages, costs or expense of repair or replacement as described above.

**WARNING** - Never use tool without proper eye protection.